

4

3

2

1

REVISIONS - 0 BALLOON DENOTES CHANGE			
REV.	DESCRIPTION	DATE	APPROVED
A		6/4/2021	

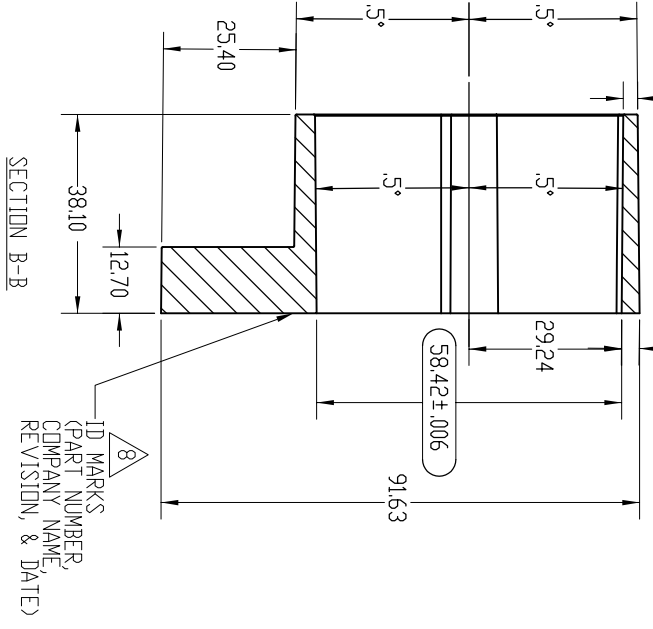
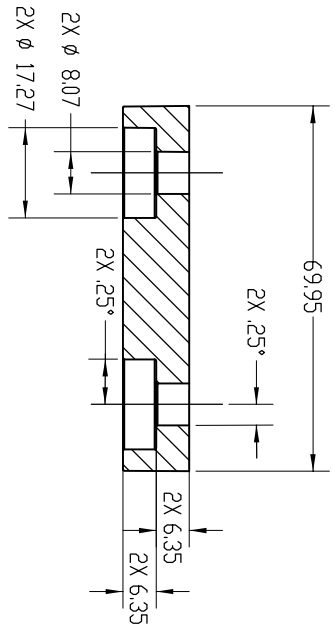
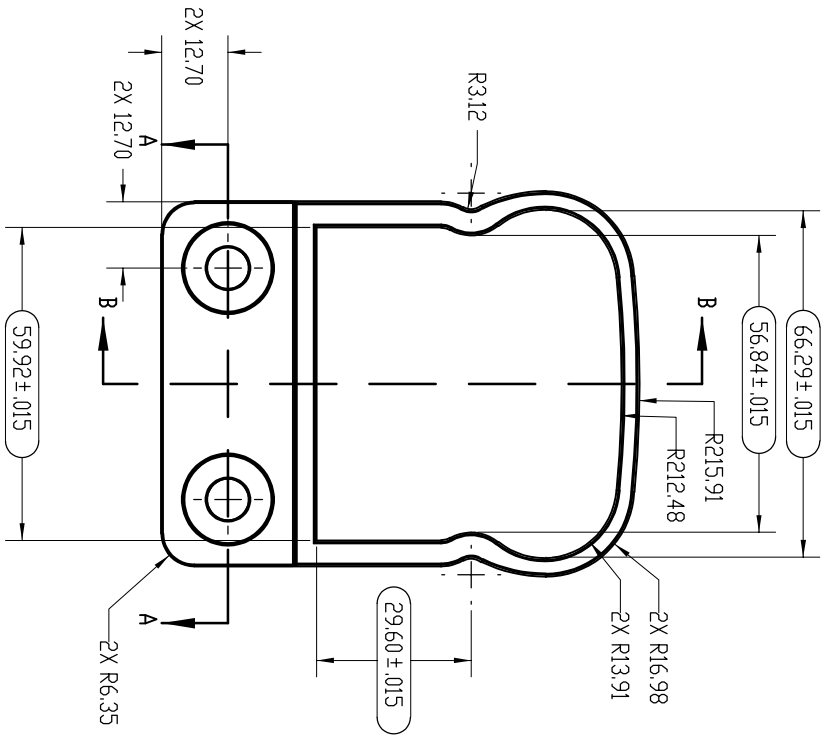

8
ID MARKS
(PART NUMBER,
COMPANY NAME,
REVISION, & DATE)

- NOTES:
- UNSPECIFIED DIMENSIONS AND DRAFT ANGLES ARE PER 3D CAD MODEL. THE MODEL IS THE MASTER.
 - MUST BE FREE FROM FLASH AND SHARP EDGES.
 - Ø INDICATES A CRITICAL DIMENSION.
 - STANDARD DRAFT ANGLE IS .5 DEG UNLESS STATED OTHERWISE.
 - ALL GATE AND EJECTOR PIN LOCATIONS TO BE APPROVED BY ULTRALOX PRIOR TO DIE MANUFACTURE.
 - DIMENSIONS APPLY BEFORE PAINT OR COATINGS. INSPECT PARTS BARE.
 - ALL UNSPECIFIED RADI MAX .254MM.
 - DEBSS VERBIAGE IF NEEDED TO KEEP FROM STICKING OUT BUT ALSO ENSURE VERBIAGE DOES NOT SHOW THROUGH TO FINISHED SIDE.
 -

UNLESS OTHERWISE SPECIFIED		NAME	DATE	
DIMENSIONS ARE IN MM		DRAWN	6/4/21	
TOLERANCES:		CHECKED		TITLE VICTORIAN WALL MOUNT CASTING
SURFACE FINISH: 125 RMS		ENG APPR		
ANGULAR: ±.5 DEG		MFG APPR		
LINEAR: .XX ±.127				SIZE DWG. NO. B
THIRD ANGLE PROJECTION		PROPRIETARY AND CONFIDENTIAL THE INFORMATION CONTAINED IN THIS DRAWING IS THE SOLE PROPERTY OF Ultralox. ANY REPRODUCTION IN PART OR AS A WHOLE WITHOUT THE WRITTEN PERMISSION OF Ultralox.		REV A
MATERIAL: A369				WEIGHT:
FINISH:				SHEET 1 OF 1
DO NOT SCALE DRAWING				

4

3

2

1